

The Red Jacket[®] Submersible Turbine Pump FE Petro[®] Conversion Kit

Installation & Parts Lists



Notice

Veeder-Root makes no warranty of any kind with regard to this publication, including, but not limited to, the implied warranties of merchantability and fitness for a particular purpose.

Veeder-Root shall not be liable for errors contained herein or for incidental or consequential damages in connection with the furnishing, performance, or use of this publication.

Veeder-Root reserves the right to change system options or features, or the information contained in this publication.

This publication contains proprietary information which is protected by copyright. All rights reserved. No part of this publication may be photocopied, reproduced, or translated to another language without the prior written consent of Veeder-Root.

Contact Red Jacket Technical Support for additional troubleshooting information at 800-323-1799.

DAMAGE GOODS/LOST EQUIPMENT

Thoroughly examine all components and units as soon as they are received. If any cartons are damaged or missing, write a complete and detailed description of the damage or shortage on the face of the freight bill. The carrier's agent must verify the inspection and sign the description. Refuse only the damaged product, not the entire shipment.

VR must be notified of any damages and/or shortages within 30 days of receipt of the shipment, as stated in our Terms and Conditions.

VEEDER-ROOT'S PREFERRED CARRIER

1. Fax Bill of Lading to V/R Customer Service at 800-234-5350.
2. Call V/R Customer Service at 800-873-3313 with the specific part numbers and quantities that were received damaged or lost.
3. VR will file the claim with the carrier and replace the damaged/missing product at no charge to the customer. Customer Service will work with production facility to have the replacement product shipped as soon as possible.

CUSTOMER'S PREFERRED CARRIER

1. Customer files claim with carrier.
2. Customer may submit a replacement purchase order. Customer Service will work with production facility to have the replacement product shipped as soon as possible.
3. If "lost" equipment is delivered at a later date and is not needed, VR will allow a Return to Stock without a restocking fee.
4. VR will NOT be responsible for any compensation when a customer chooses their own carrier.

RETURN SHIPPING

For the parts return procedure, please follow the instructions in the "General Returned Goods Policy" pages of the "Policies and Literature" section of the Veeder-Root North American Red Jacket Mechanical Products Price Book. Veeder-Root will not accept any return product without a Return Goods Authorization (RGA) number clearly printed on the outside of the package.

Introduction

Introduction 1
 Manuals Required 1
 Installers 1
 Safety Precautions 1
 Warnings and Instructions 3
 Preliminary Precautions..... 3
 REQUIREMENTS FOR USE..... 4
 OPERATING PRECAUTIONS 4
 Conversion Kits List 4
 UMP Model List 5
 Fuel Compatibilities 5
 UMP Electrical Service Information 6
 UMP Model Dimensions 6

Installation

UMP Removal, Replacement And Electrical Connector (Pigtail) Removal,
 Replacement 7
 Procedure 7
 Capacitor Installation (Only For Kits 410983-001, -002, -005, And -006) 8
 Identification Plate Installation 8
 Procedure: 8
 Control Box Installation 9
 Start Up Of The Pumping System 12

Parts Lists

Capacitor Kits 13
 Pump Parts 13
 Control Boxes 13
 IQ Control Boxes 14
 Customer Service Number 14

Figures

Figure 1. Installing Capacitor 8
 Figure 2. 230 Vac Remote Control Box With 110 Vac Coil
 (Capacitor Installed in Manifold) – Model 880-041-5 9
 Figure 3. 230 Vac Remote Control Box With 230 Vac Coil
 (Capacitor Installed in Manifold) – Model 880-042-5 10
 Figure 4. 240 Vac Remote Control Box With 120 Vac Coil And
 Capacitor (Model 410861-001) 11
 Figure 5. 240 Vac Remote Control Box With 240 Vac Coil And
 Capacitor (Model 410860-001) 12
 Figure 6. Control Box W/O Capacitor 13
 Figure 7. Control Box W/Capacitor 14

Introduction

Introduction

The purpose of the kits described in this manual are to convert an FE Petro®, variable speed pump to a Veeder-Root fixed speed pump with a single-phase control box. Pump components described throughout the manual are FE Petro® terminology followed by the equivalent Veeder-Root term in parentheses. Example: electrical connector (pigtail).

When changing-out an FE Petro®, variable speed motor with a Veeder-Root fixed speed motor, be sure to check the length (see tables on page 4) so that proper clearance off the tank bottom is maintained (4 to 5in [100 to 125mm] for standard and Trapper™ UMPs and 14in [355mm] for UMPs with a floating suction adapter). If adjusting the pump length is required and the piping is fixed length, for assistance contact FE Petro® Technical Support at (800) 225-9787.

Manuals Required

- FE Petro® Manual 400604005 STP/IST Fixed & Variable Length Installation and Owner's Manual
- FE Petro® Manual 400289002 Pump Motor Assembly Replacement Instructions





▲WARNING The Veeder-Root, fixed speed UMP requires single phase power. The site power must match in order safely operate the UMP.







Installers

Only trained or authorized individuals knowledgeable in the related procedures should install, inspect, maintain or service this equipment.





Safety Precautions

The following safety symbols are used throughout this manual to alert you to important safety hazards and precautions.

 <p>EXPLOSIVE Fuels and their vapors are extremely explosive if ignited.</p>	 <p>FLAMMABLE Fuels and their vapors are extremely flammable.</p>
 <p>ELECTRICITY High voltage exists in, and is supplied to, the device. A potential shock hazard exists.</p>	 <p>TURN POWER OFF Live power to a device creates a potential shock hazard. Turn Off power to the device and associated accessories when servicing the unit.</p>
<p>▲WARNING WARNING indicates a hazardous situation which, if not avoided, could result in death or serious injury.</p>	<p>▲CAUTION CAUTION indicates a hazardous situation which, if not avoided, could result in minor or moderate injury.</p>

 <p>WEAR EYE PROTECTION Wear eye protection when working with pressurized fuel lines to avoid possible eye injury.</p>	<p>NOTICE is used to address practices not related to physical injury.</p>
 <p>WEAR GLOVES Wear gloves to protect hands from irritation or injury.</p>	 <p>NO POWER TOOLS Sparks from power tools (such as drills) can ignite fuels and their vapors.</p>
 <p>NO SMOKING Sparks and embers from burning cigarettes or pipes can ignite fuels and their vapors.</p>	 <p>NO OPEN FLAMES Open flames from matches, lighters, welding torches, etc. can ignite fuels and their vapors.</p>
 <p>READ ALL RELATED MANUALS Knowledge of all related procedures before you begin work is important. Read and understand all manuals thoroughly. If you do not understand a procedure, ask someone who does</p>	 <p>TURN OFF CELL PHONES/PAGERS Sparks from electronic devices in the vicinity of gasoline storage tanks could cause an explosion or fire resulting in bodily injury or death.</p>

⚠ WARNING

This product operates in the highly combustible atmosphere of a gasoline storage tank. **FAILURE TO COMPLY WITH THE FOLLOWING WARNINGS AND SAFETY PRECAUTIONS COULD CAUSE DAMAGE TO PROPERTY, ENVIRONMENT, RESULTING IN SERIOUS INJURY OR DEATH.**

1. All installation work must comply with the latest issue of the National Electrical Code (NFPA 70), the Code for Motor Fuel Dispensing Facilities and Repair Garages (NFPA 30A), and any European, national, state, and local code requirements that apply.
2. Turn off, tag, and lockout power to the STP before connecting or servicing the STP.
3. Before installing pipe threads apply an adequate amount of fresh, UL classified for petroleum, non-setting thread sealant. For AG applications, Loctite 564 is recommended for all field serviceable pipe threads.
4. When servicing unit, use non-sparking tools and use caution when removing or installing equipment to avoid generating a spark.
5. To protect yourself and others from serious injury, death, or substantial property damage, carefully read and follow all warnings and instructions in this manual.

Warnings and Instructions

▲WARNING This section introduces the hazards and safety precautions associated with installing, inspecting, maintaining or servicing this product. Before performing any task on this product, read this safety information and the applicable sections in this manual, where additional hazards and safety precautions for your task will be found. Fire, explosion, electrical shock or pressure release could occur and cause damage to property, environment, resulting in serious injury or death, if these safe service procedures are not followed.

PRELIMINARY PRECAUTIONS

▲WARNING You are working in a potentially dangerous environment of flammable fuels, vapors, and high voltage or pressures. Only trained or authorized individuals knowledgeable in the related procedures should install, inspect, maintain or service this equipment.



Read The Manual

Read, understand and follow this manual and any other labels or related materials supplied with this equipment. If you do not understand a procedure, call 1-800-323-1799 to locate a qualified technician. It is imperative to your safety and the safety of others to understand the procedures before beginning work. **Make sure your employees and any service contractors read and follow the instructions.**

Follow The Regulations

Applicable information is available in National Fire Protection Association (NFPA) 30A; *Code for Motor Fuel Dispensing Facilities and Repair Garages*, NFPA 70; *National Electrical Code* (NEC), Occupational Safety and Hazard Association (OSHA) regulations and federal, state, and local codes. All these regulations must be followed. Failure to install, inspect, maintain or service this equipment in accordance with these codes, regulations and standards may lead to legal citations with penalties or affect the safe use and operation of the equipment.

Prevent Explosions and Fires

Fuels and their vapors will explode or burn, if ignited. Spilled or leaking fuels cause vapors. Even filling customer tanks will cause potentially dangerous vapors in the vicinity of the dispenser or island.

Working Alone

It is highly recommended that someone who is capable of rendering first aid be present during servicing. Familiarize yourself with Cardiopulmonary Resuscitation (CPR) methods, if you work with or around high voltages. This information is available from the American Red Cross. Always advise the station personnel about where you will be working, and caution them not to activate power while you are working on the equipment. Use the OSHA Lockout/Tagout procedures. If you are not familiar with this requirement, refer to OSHA documentation.

Working With Electricity Safely

Ensure that you use safe and established practices in working with electrical devices. Poorly wired devices may cause a fire, explosion or electrical shock. Ensure that grounding connections are properly made. Ensure that you do not pinch wires when replacing covers. Follow OSHA Lockout/Tagout requirements. Station employees and service contractors need to understand and comply with this program completely to ensure safety while the equipment is down. Before you start work, know the location of the Emergency Power Cutoff Switch (the E-STOP). This switch cuts off power to all fueling equipment and submerged turbine pumps and is to be used in the event of an emergency. The buttons on the console at the cashier's station WILL NOT shut off electrical power to the pump/dispenser. This means that even if you press a button on the console labeled EMERGENCY STOP, ALL STOP, PUMP STOP, or something similar, fuel may continue to flow uncontrolled.

the pump/dispenser. This means that even if you press a button on the console labeled EMERGENCY STOP, ALL STOP, PUMP STOP, or something similar, fuel may continue to flow uncontrolled.

Hazardous Materials

Some materials may present a health hazard if not handled correctly. Ensure that you clean hands after handling equipment. Do not place any equipment in the mouth.

⚠ WARNING FAILURE TO COMPLY WITH THE FOLLOWING WARNINGS AND SAFETY PRECAUTIONS COULD RESULT IN PROPERTY DAMAGE, INJURY OR DEATH.



FIRE HAZARD! Do **NOT** use **power tools** (Class I Division I and Class I Division II) during the installation or maintenance of equipment. Sparking could ignite fuel or vapors, resulting in fire.

CHEMICAL EXPOSURE HAZARD! Wear appropriate **safety equipment** during installation or maintenance of equipment. Avoid exposure to fuel and vapors. Prolonged exposure to fuel may cause severe skin irritations and possible burns.

REQUIREMENTS FOR USE

- The Red Jacket is designed for use only at facilities dispensing motor fuels.
- Application of The Red Jacket must be consistent with NFPA Code 30A, OSHA regulations, and federal, state and local fire codes, and other applicable local regulations.
- The selection of any Veeder-Root product must be based upon physical specifications and limitations and the product’s compatibility with the materials to be handled. Veeder-Root makes no warranty of fitness for a particular purpose.
- All Veeder-Root products should be used in accordance with applicable federal, state and local laws, ordinances and regulations.

OPERATING PRECAUTIONS



NO SMOKING. Extinguish all open flames and pilot lights, such as on RV appliances.

TURN OFF cell phones and other electronic devices to prevent sparks which could cause an explosion or fire.

Conversion Kits List

The correct conversion kit to order is determined by the required dispense enable voltage (120V or 240V), control box preference (Standard or IQ) to replace the FE Petro® MagVFC, and capacitor location preference (installed in manifold or control box).

Capacitor Installed In STP Junction Box	Standard Control Box	Dispense Enable Voltage	Order Kit Part Number
		120V	410893-001
		240V	410893-002
	IQ Control Box	Dispense Enable Voltage	Order Kit Part Number
		120V	410893-005
		240V	410893-006

Capacitor Installed In Control Box	Standard Control Box	Dispense Enable Voltage	Order Kit Part Number
		120V	410893-003
		240V	410893-004
	IQ Control Box	Dispense Enable Voltage	Order Kit Part Number
		120V	410893-007
		240V	410893-008

410893-001: contains 120v Control Box P/N 880-041-5 and 40 μ Fd capacitor kit P/N 410901-001

410893-002: contains 240v Control Box P/N 880-042-5 and 40 μ Fd capacitor kit P/N 410901-001

410893-003: contains 120v Control Box w/ 40 μ Fd capacitor installed P/N 410861-001

410893-004: contains 240v Control Box w/ 40 μ Fd capacitor installed P/N 410860-001

410893-005: contains 120v IQ Box P/N 880-051-1 and 40 μ Fd capacitor kit P/N 410901-001

410893-006: contains 240v IQ Box P/N 880-052-1 and 40 μ Fd capacitor kit P/N 410901-001

410893-007: contains 120v IQ Box w/ 40 μ Fd capacitor installed P/N 880-058-1

410893-008: contains 240v IQ Box w/ 40 μ Fd capacitor installed P/N 880-059-1

All conversion kits listed above also contain the following components:

- 4" Pigtail 20 FT Kit; P/N 410156-001
- Conversion Kit Installation Instruction Manual; P/N 577014-365
- Identification Plate w/ Attachment Wire

UMP Model List

The correct UMP is determined by the fuel application and is based on the 'Fuel Compatibilities' section below.

- UMP200U1-3 Pump Motor Assembly w/ Fastener Kit; P/N 852-221-5
- AGUMP200S1-3 Pump Motor Assembly w/ Fastener Kit; P/N 852-222-5

Fuel Compatibilities

The Red Jacket UMP200U1-3 UMP is designed to be compatible with 100 percent gasoline, or diesel and 80 percent gasoline with 20 percent methanol, ethanol, TAME, ETBE, MTBE. BioDiesel B5.

Maximum Specific Gravity of the fuel pumped by the UMP200U1-3 is 0.87 and the Maximum Viscosity is 70 SSU at 60°F (15°C).

Approximate Pump Shut Off Pressures of the UMP200U1-3 is 43 psi (297 kPa)(0.74 SG @ 60°F (15°C)).

UMPs having the AG prefix are designed to be compatible with 100 percent gasoline, methanol and 90 percent ethanol with 10 percent gasoline and 80 percent gasoline with 20 percent TAME, ETBE, MTBE; and 100 percent diesel, diesel and up to 100 percent biodiesel; kerosene, fuel oil, avgas and jet fuel.

UMP Electrical Service Information

UMP Model No.	HP	Hz	PH	Voltage Fluctuation Range		Max. Load Amps	Locked Rotor Amps	Winding Resistance (Ohms)		
				Min.	Max.			Black-Orange	Red-Orange	Black-Red
AGUMP200S1-3, UMP200U1-3	2	60	1	200	250	11.4	44	1.9 - 2.3	3.4 - 4.1	5.1 - 6.2

UMP Model Dimensions

Veeder-Root UMP Model	HP	Length		Weight	
		In.	mm	lb.	kg
AGUMP200S1-3, UMP200U1-3	2	24-5/8	626	36	16.3

FE Petro® PMA Model	HP	Length	
		In.	mm
IST/STPV2	2 Variable Speed	20	508
ISTVS4/STPVS4	4 Variable Speed	25	635

Installation

UMP Removal, Replacement And Electrical Connector (Pigtail) Removal, Replacement

▲WARNING



Disconnect, lock out, and tag power at the panel before servicing the pump.

Procedure

1. Refer to FE Petro® manual 400289002 for FE Pump Motor Assembly (PMA) removal instructions.
2. Remove the manifold discharge head (packer) wiring compartment cover (See FE Petro® Manual 400604005). Set aside the cover. Observe the three wiring connections in the compartment. Make a note of which wire from the manifold discharge head (packer) connects to which wire from the electrical connector (pigtail) (it should be like colored wires connecting to like colored wires). Disconnect the wires and set aside the wire nuts.
3. Look at the end of the motor discharge head. Pull the electrical connector (pigtail) out of its socket in the motor discharge head. Remove the electrical connector (pigtail) and cut off one of the wires to use as a pull wire for the new pigtail. Discard the electrical connector (pigtail).
4. Get the new electrical connector (pigtail) assembly and uncoil the electrical connector (pigtail) so it lays flat.
5. Push the electrical connector (pigtail) wires into the motor discharge head socket until they exit into the manifold discharge head (packer)'s wiring compartment. At the discharge (connector) end of the electrical connector (pigtail), rub some petroleum jelly over the connector's outside surface and push it into its socket in the motor discharge head. Take care to align the connector index tab with the notch in the socket.
6. Place the new gasket from the UMP replacement kit on the new UMP so that all the holes align.

▲CAUTION

You are working in a potentially dangerous environment of flammable fuels, vapors, and high voltage or pressures. Only trained or authorized individuals knowledgeable in the related procedures should install, inspect, maintain or service this equipment.

7. Align the UMP positioning dowel so it inserts in the proper hole in the discharge head and push the UMP into position using hand force only. The UMP should be snug against the discharge head prior to installing the UMP retaining bolts.

▲WARNING

Use hand force to push the UMP onto the discharge head. If the UMP does not seat snug against the discharge head, remove the UMP and correct the problem.

8. Install the four UMP retaining bolts and lock washers. Snug and then torque the bolts using a cross pattern technique to 7 ft-lbs (11 N•m).

▲WARNING

Do not over torque the bolts. Not following these instructions may cause parts to fail.

9. Carefully pull on the electrical connector (pigtail) wires where they exit the manifold discharge head (packer) wiring compartment until any excess length is out of the column pipe. Cut off the electrical connector (pigtail) wires approximately 8 inches (200 mm) beyond the top of the manifold discharge head (packer).
10. Strip insulation off the three electrical connector (pigtail) wires 3/8 inch (10 mm).
11. Connect like colored wires from the electrical connector (pigtail) to like colored wires from the manifold discharge head (packer) connector with wire nuts. When finished connecting the wires, neatly coil wires inside the manifold discharge head's (packer) wiring compartment.
12. Refer to FE Petro® manual 400289002 for extractable re-installation instructions.

Capacitor Installation (Only For Kits 410983-001, -002, -005, And -006)

▲WARNING



Disconnect, lock out, and tag power at the panel before servicing the pump.

1. Remove junction box cover (see FE Petro® manual 400604005).
2. Disconnect black and red wires only.
3. Terminate the end of the red power lead wire.
4. Strip back 3/8" (10mm) of insulation on the red and black wires from the wire connector assembly and the black power lead wire from the supply.
5. Route these wires through hole(s) in the capacitor terminal cover.
6. Wire capacitor as shown in Figure 1 using capacitor terminal cover wires and wire nuts provided. Use red wire provided to connect red wire from wire connector assembly to one capacitor terminal. Use one black wire provided to connect black wire from the wire connector assembly to the opposite capacitor terminal. Use other black wire provided to connect the black power lead wire to the capacitor terminal already wired with black wire from wire connector assembly.
7. Verify that all connections are proper.
8. Install capacitor terminal cover over capacitor terminals.
9. Install capacitor in junction box.
10. Replace junction box cover and torque to ensure flange-to-flange contact.

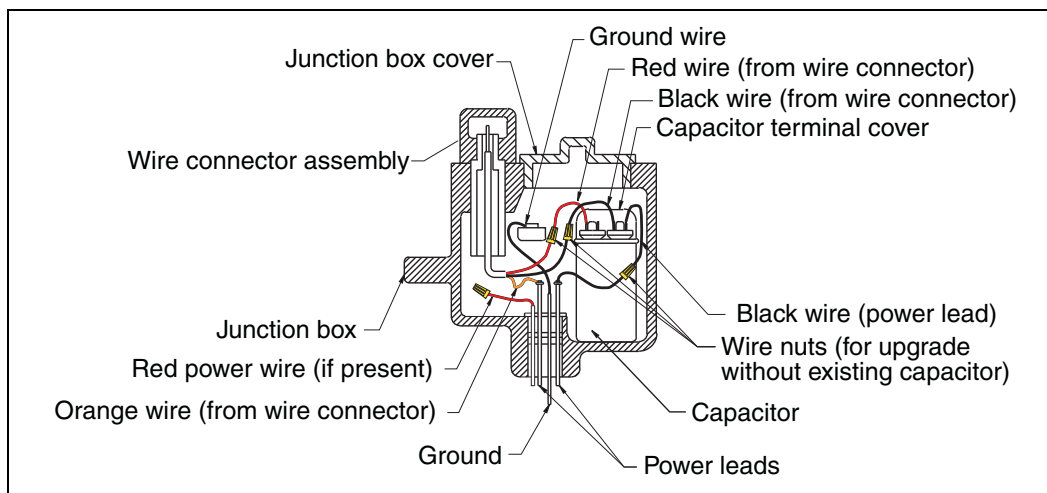

Figure 1. Installing Capacitor

Identification Plate Installation

Procedure:

1. Feed the metal wire tie through a hole in the identification plate.
2. Wrap the wire tie around the wire connection assembly (yoke) (See Manual 400604005).

- Twist the two wire tie ends together to ensure the identification plate is securely attached.

Control Box Installation

⚠ WARNING



Disconnect, lock out, and tag power at the panel before servicing the pump.

For IQ Control Box installation and wiring, refer to Veeder-Root manual D051-330 provided with the IQ Control Box.

Refer to Figure 2 through Figure 5 below for Standard Control Box installation and wiring diagrams.

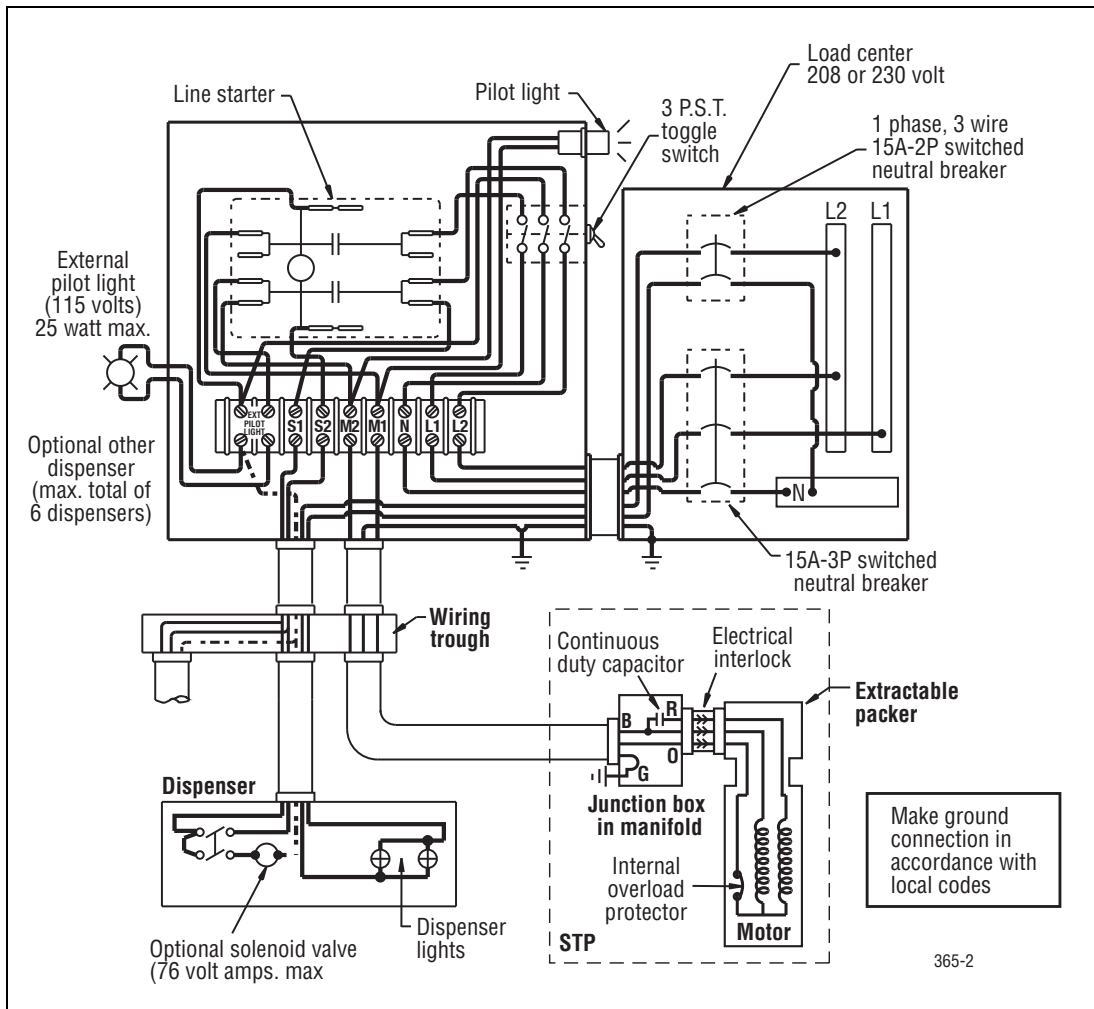

Figure 2. 230 Vac Remote Control Box With 110 Vac Coil (Capacitor Installed in Manifold) – Model 880-041-5

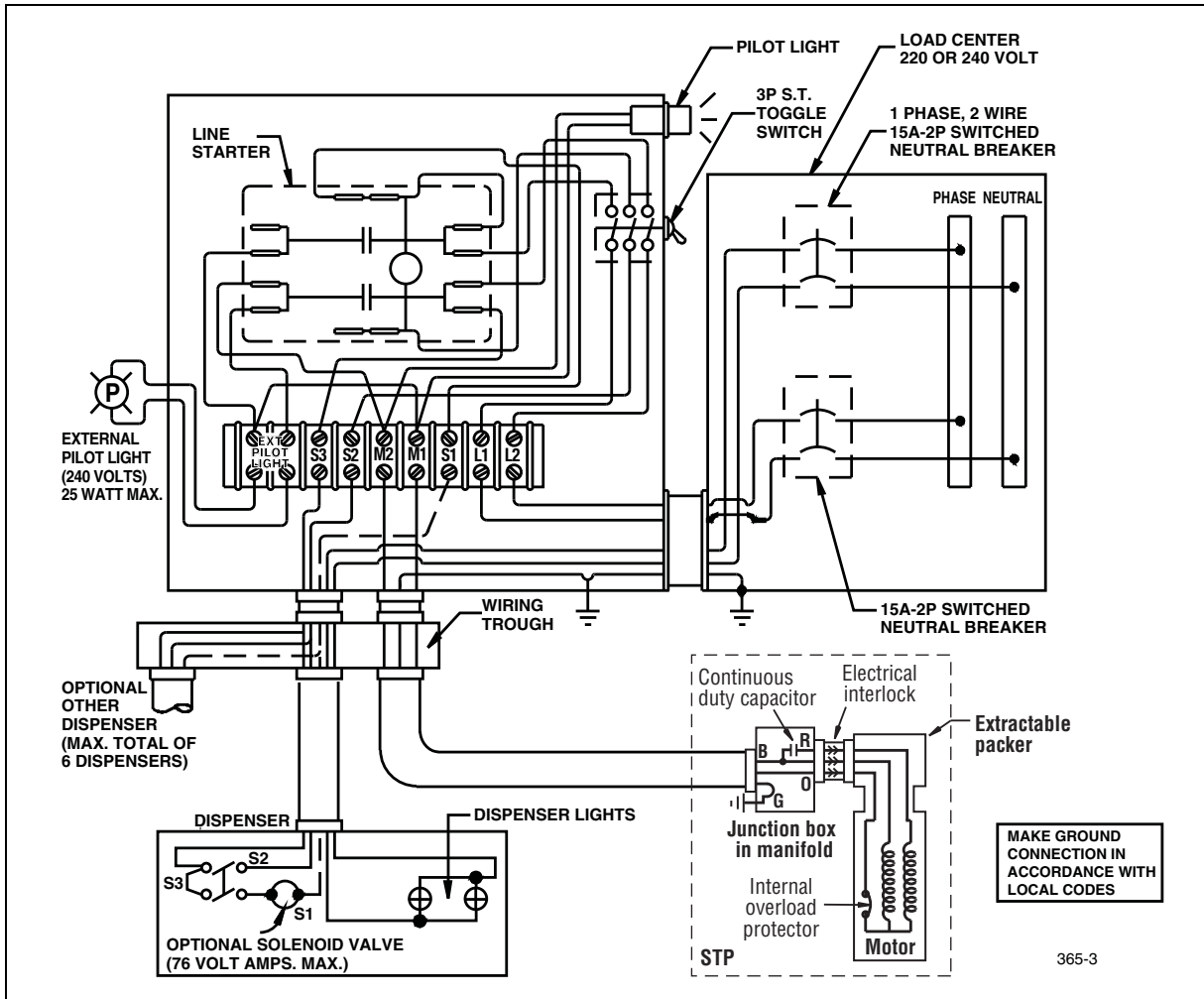

Figure 3. 230 Vac Remote Control Box With 230 Vac Coil (Capacitor Installed in Manifold) – Model 880-042-5

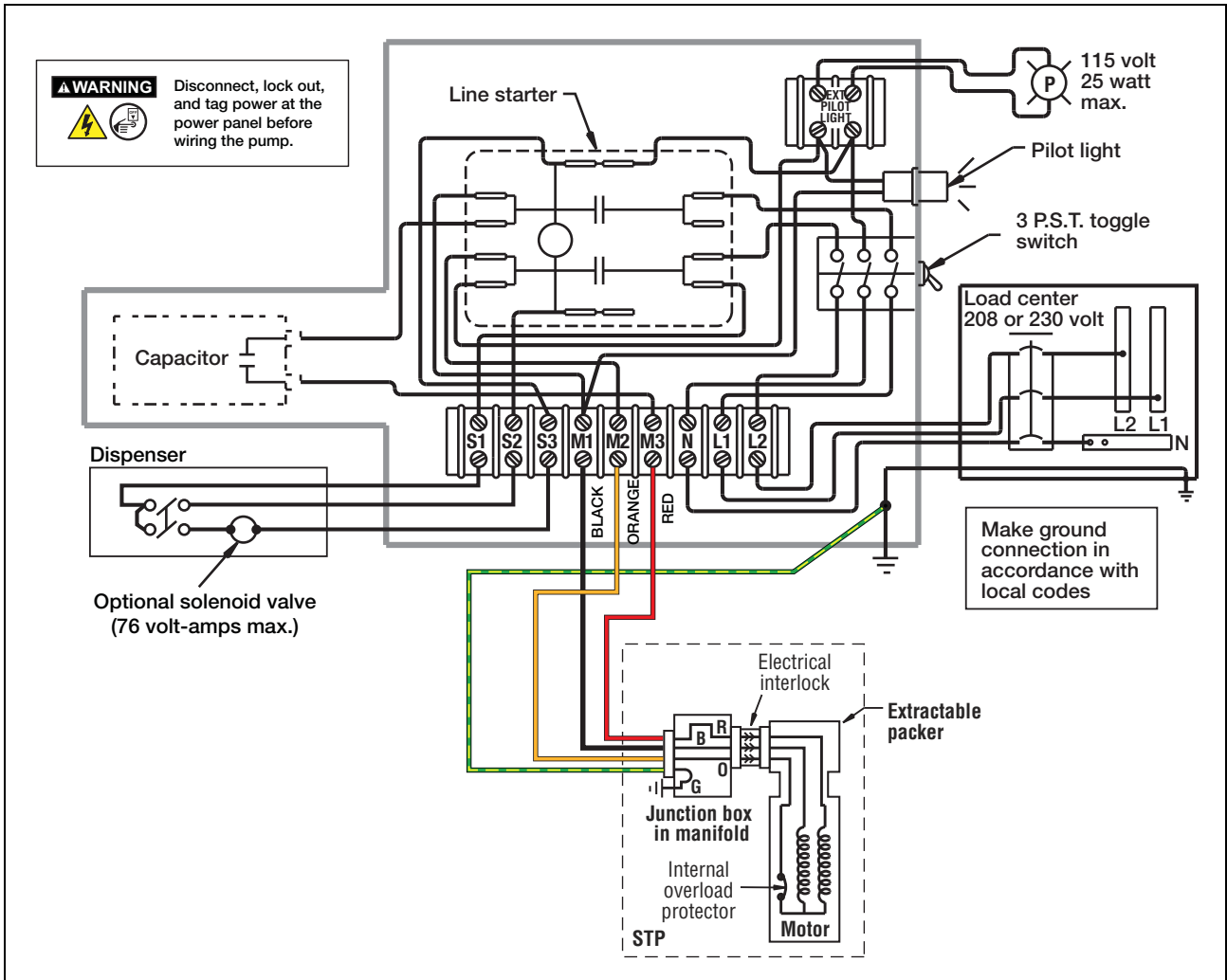

Figure 4. 240 Vac Remote Control Box With 120 Vac Coil And Capacitor (Model 410861-001)

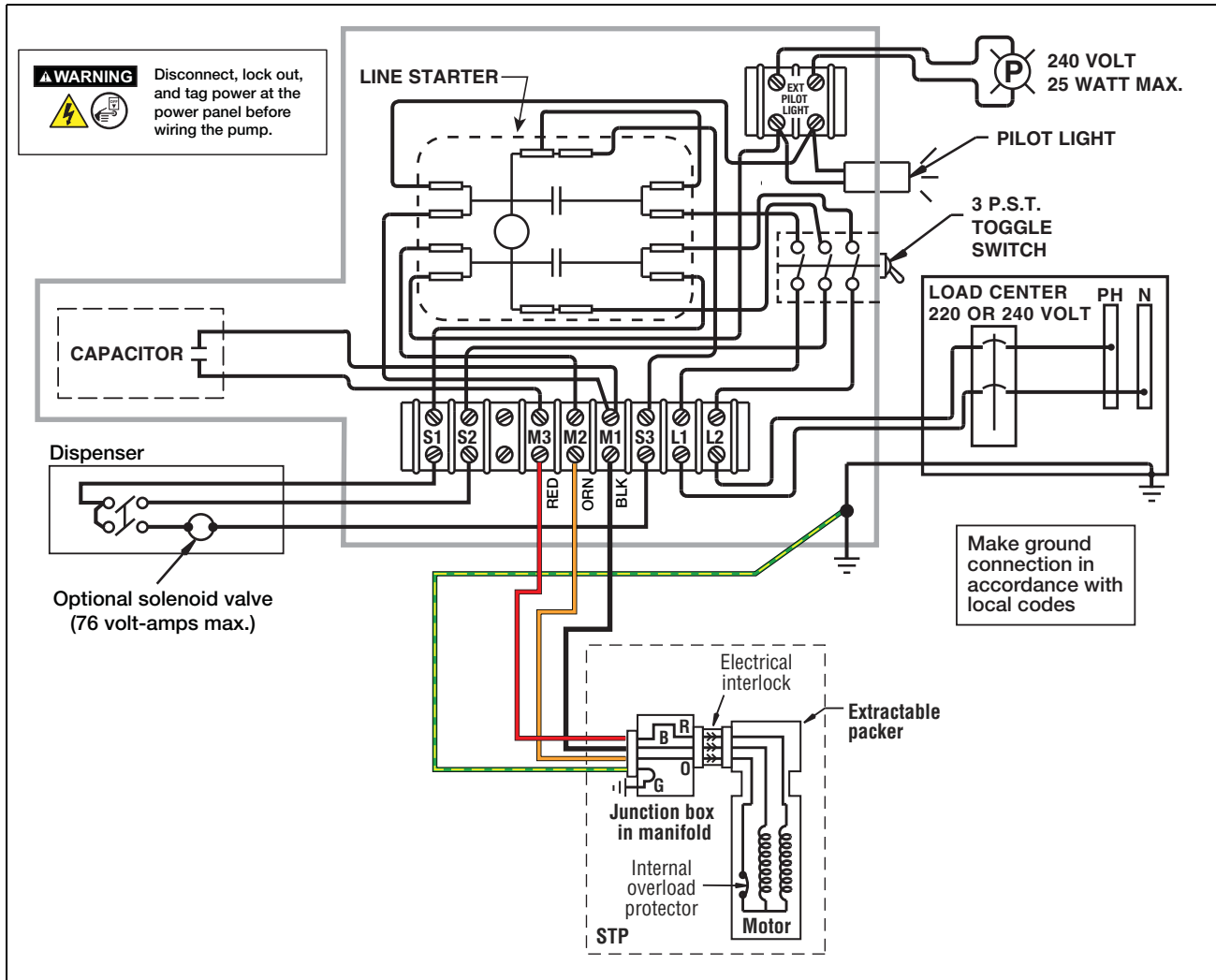

Figure 5. 240 Vac Remote Control Box With 240 Vac Coil And Capacitor (Model 410860-001)

Start Up Of The Pumping System

Refer to FE Petro® manual 400289002 to re-engage the pumping system.
 For help or assistance call Veeder-Root Technical Support 1-800-323-1799.

Parts Lists

Capacitor Kits

For capacitor located in the STP junction box, the capacitor kit is 410901-001.

Pump Parts

- 4" pigtail, 20 ft kit, P/N 410156-001
- UMP w/fastener kit, P200U1-3, P/N 852-221-5
- AG UMP w/fastener kit, AGUMP200S1-3, P/N 852-222-5

Refer to FE Petro® manual 400289002 for all other replacement parts

Control Boxes

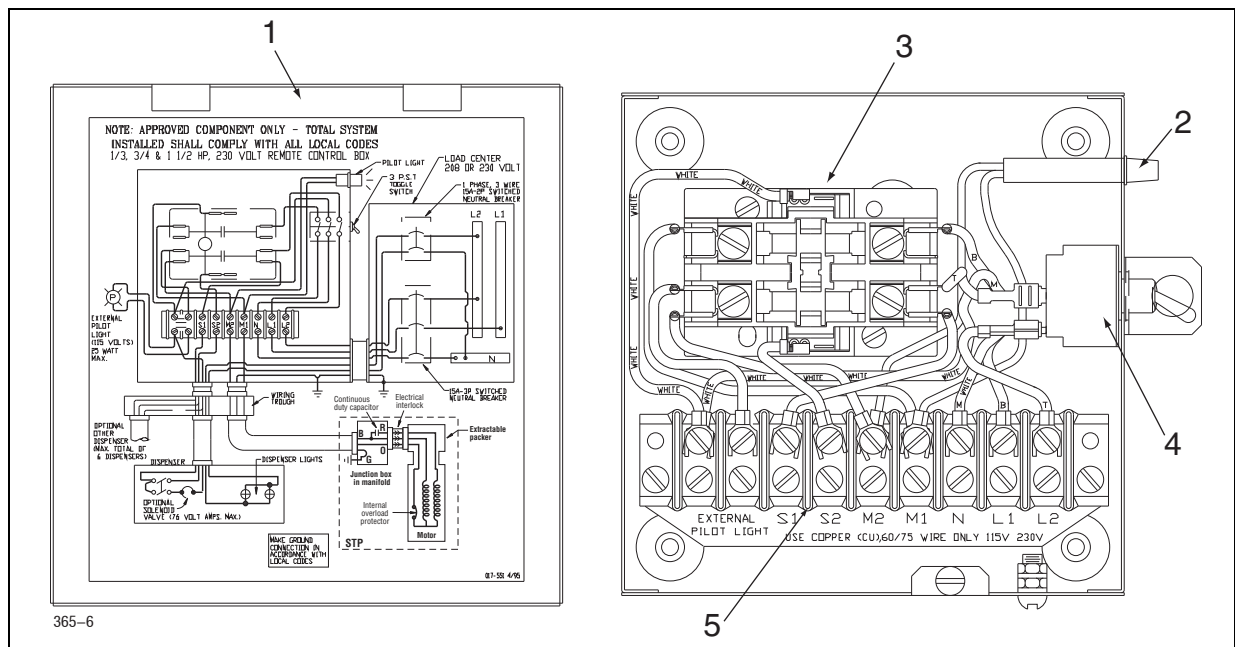

Figure 6. Control Box W/O Capacitor

Figure 6 Item	Part Number	Description	P/N 880-041-5	P/N 880-042-5
			CB-2HP 120V Coil	CB-2HP 240V Coil
1	108-572-4	Control box	1	1
2	147-006-1	Pilot light ass'y.	1	1
3	1	Line contractor relay	014-723-1	014-720-1
4	080-858-1	Toggle switch	1	1
5	008-202-1	Terminal block	1	1

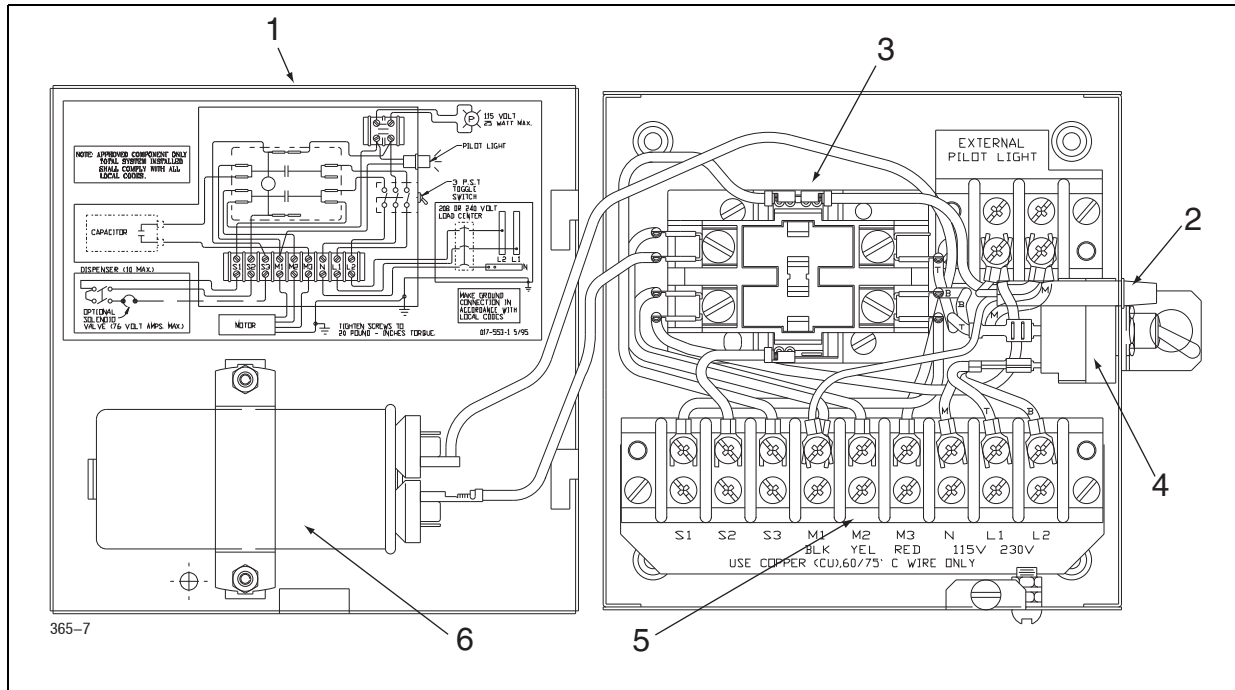

Figure 7. Control Box W/Capacitor

Figure 7 Item	Part Number	Description	880-041-5	880-042-5
			CB-2HP 40 µF 120V Coil	CB-2HP 40 µF 240V Coil
1	1	Control box	410164-003	410164-003
2	1	Pilot light ass'y.	014-723-1	014-720-1
3	247-001-5	Line contractor relay	1	1
4	080-858-1	Toggle switch	1	1
5	008-202-1	Terminal block	1	1

IQ Control Boxes

IQ Control Box Description	CB- 2 HP 120V Coil No Capacitor	CB- 2 HP 240V Coil No Capacitor	CB- 2 HP 120V Coil With 40 µF Capacitor	CB- 2 HP 120V Coil With 40 µF Capacitor
Part Number	880-051-1	880-052-1	880-058-1	880-059-1

Customer Service Number

After unpacking the equipment, please inspect the parts. Make sure all accessories are included and that no damage occurred during shipping. Report any damage to the shipper immediately and inform a customer service representative at 1-800-873-3313 of any equipment damage or missing parts.

